

# ZXSC100

## SINGLE CELL DC-DC CONVERTER SOLUTION

### DESCRIPTION

The ZXSC100 series is designed for DC-DC applications where step-up voltage conversion from very low input voltages is required. These applications mainly operate from single nickel cadmium or nickel metal hydride battery cells.

The circuit can start up under full load with regulation maintained down to an input voltage of only 0.926 volts. The solution configuration ensures optimum efficiency over a wider range of load currents, several circuit configurations are possible with power dissipation up to 2W. The step up output voltage is easily programmed with external resistors, the non-synchronous architecture and SuperSOT4™ device enabling an output voltage down to the input voltage level. For best performance the ZXSC100 quiescent current is a small 150µA ensuring minimum battery drain in no load conditions.

The IC and discrete combination offers the ultimate cost vs performance solution for single cell DC-DC conversion.

### FEATURES

- Efficiency maintained over a wide range of input voltages and load currents  
82% efficiency @  $V_{BATT}=1V$
- Startup under full load
- Minimum operating input voltage  $V_{BATT}=0.926V$
- Adjustable output voltage down to  $V_{BATT}$
- Quiescent current typically 150µA referred to input voltage
- MSOP8 package
- SO8 package

### APPLICATIONS

- Cordless telephones
- MP3 players
- PDA
- Pagers
- Battery backup supplies
- Electronic toothbrush
- GPS receivers
- Digital camera
- Palmtop computers

### APPLICATIONS(continued)

- Hand held instruments
- Portable medical equipment
- Solar powered equipment

### TYPICAL APPLICATION CIRCUIT

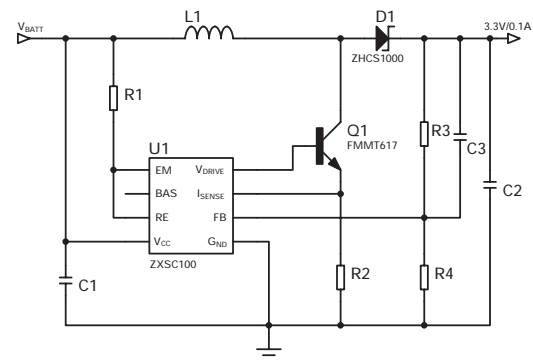

### ORDERING INFORMATION

DEVICE	Package	Partmarking	Reel size	Tape width	Quantity per reel
ZXSC100X8	MSOP8	ZXSC100	7"	12mm	1,000
ZXSC100N8	SO8	ZXSC100	7"	12mm	500

# ZXSC100

## ABSOLUTE MAXIMUM RATING

Supply voltage	0.3 to 3.5V	Operating temperature	0 to 70°C
Maximum voltage other pins	0.3 to $V_{CC}+0.3V$	Storage temperature	-55 to 150°C
Power dissipation (25°C)		Junction temperature	150°C
MSOP8	500mW		
SO8	780mW		

## ELECTRICAL CHARACTERISTICS (Unless otherwise stated) $V_{CC}=1.2V$ , $T_A = 25^\circ C$

Symbol	Parameter	Conditions	Min.	Typ.	Max.	Units
$I_{CC}$	Quiescent current	Not switching		150	200	$\mu A$
$I_{DRIVE}$	Base drive current	$V_{RE} = V_{CC}$	5		10	mA
$V_{DRIVE}$	$V_{DRIVE}$ o/p voltage	$V_{RE} = V_{CC}$ , $I_{DRIVE} = 5mA$	$V_{CC} - 0.17$			V
$V_{FB}$	Feedback voltage		708	730	752	mV
$V_{ISENSE}$	Output current reference voltage		12	17.5	24	mV
$T_{CVISENSE}$	$I_{SENSE}$ voltage temp co.			0.4		%/°C
$V_{DREF}$	Drive current reference voltage	Measured with respect to $V_{CC}$	20	30	40	mV
$T_{CVDREF}$	$V_{DREF}$ temp co.			1		%/°C
$V_{CC(SRT)}$	Startup voltage	Any output load	1.01	1.06	1.1	V
$V_{CC(min)}$	Minimum operating input voltage		0.926	0.98	1	V
$V_{CC(hys)}$	Supply start up to shutdown hysteresis			80		mV
$I_{FB}$	Feedback input current			100	200	nA
$I_{ISENSE}$	$I_{SENSE}$ input current	$V_{ISENSE} = 0V$	3	4	5.5	$\mu A$
$V_{O(min)}$	Minimum output voltage		$V_{CC}$			V
$V_{O(max)}$	Maximum output voltage	FM6T617as pass element <sup>(1)</sup>			20	V
$T_{OFF}$	Discharge pulse width		1.7	3	4	$\mu s$

(1) Depends on breakdown voltage of pass device. See FM6T617 datasheet

# ZXSC100

## OPERATING CONDITIONS

Symbol	Parameter	Conditions	Min	Typ	Max	Units
F <sub>osc</sub>	Recommended operating frequency <sup>3</sup>				200	kHz

<sup>2</sup> These parameters guaranteed by design and characterization

<sup>3</sup> Operating frequency is application circuit dependant. See applications section

## FMMT617

For the circuits described in the applications section, Zetex FMMT617 is the recommended pass transistor. The following indicates outline data for the transistor, more detailed information can be found at [www.zetex.com](http://www.zetex.com)

## ELECTRICAL CHARACTERISTICS (at T<sub>A</sub> = 25°C unless otherwise stated)

PARAMETER	SYMBOL	MIN.	TYP.	MAX.	UNIT	CONDITIONS
Collector-emitter breakdown voltage	V <sub>(BR)CEO</sub>	15	18		V	I <sub>C</sub> =10mA*
Collector-emitter saturation voltage	V <sub>CE(sat)</sub>		8	14	mV	I <sub>C</sub> =0.1A, I <sub>B</sub> =10mA*
			70	100	mV	I <sub>C</sub> =1A, I <sub>B</sub> =10mA*
			150	200	mV	I <sub>C</sub> =3A, I <sub>B</sub> =50mA*

\*Measured under pulsed conditions. Pulse width=300μs. Duty cycle ≤ 2%

## ZHCS1000

For the circuits described in the applications section Zetex ZHCS1000 is the recommended Schottky diode. The following indicates outline data for the ZHCS, more detailed information is available at [www.zetex.com](http://www.zetex.com)

## ELECTRICAL CHARACTERISTICS (at T<sub>amb</sub> = 25°C unless otherwise stated)

PARAMETER	SYMBOL	MIN.	TYP.	MAX.	UNIT	CONDITIONS
Forward voltage	V <sub>F</sub>			500	mV	I <sub>F</sub> =1A
Reverse current	I <sub>R</sub>			100	μA	V <sub>R</sub> =30V
Reverse recovery time	t <sub>rr</sub>		12		ns	Switched from I <sub>F</sub> = 500mA to I <sub>R</sub> = 500mA. Measured at I <sub>R</sub> =50mA

\*Measured under pulsed conditions. Pulse width=300μs. Duty cycle ≤ 2%

# ZXSC100

## TYPICAL CHARACTERISTICS

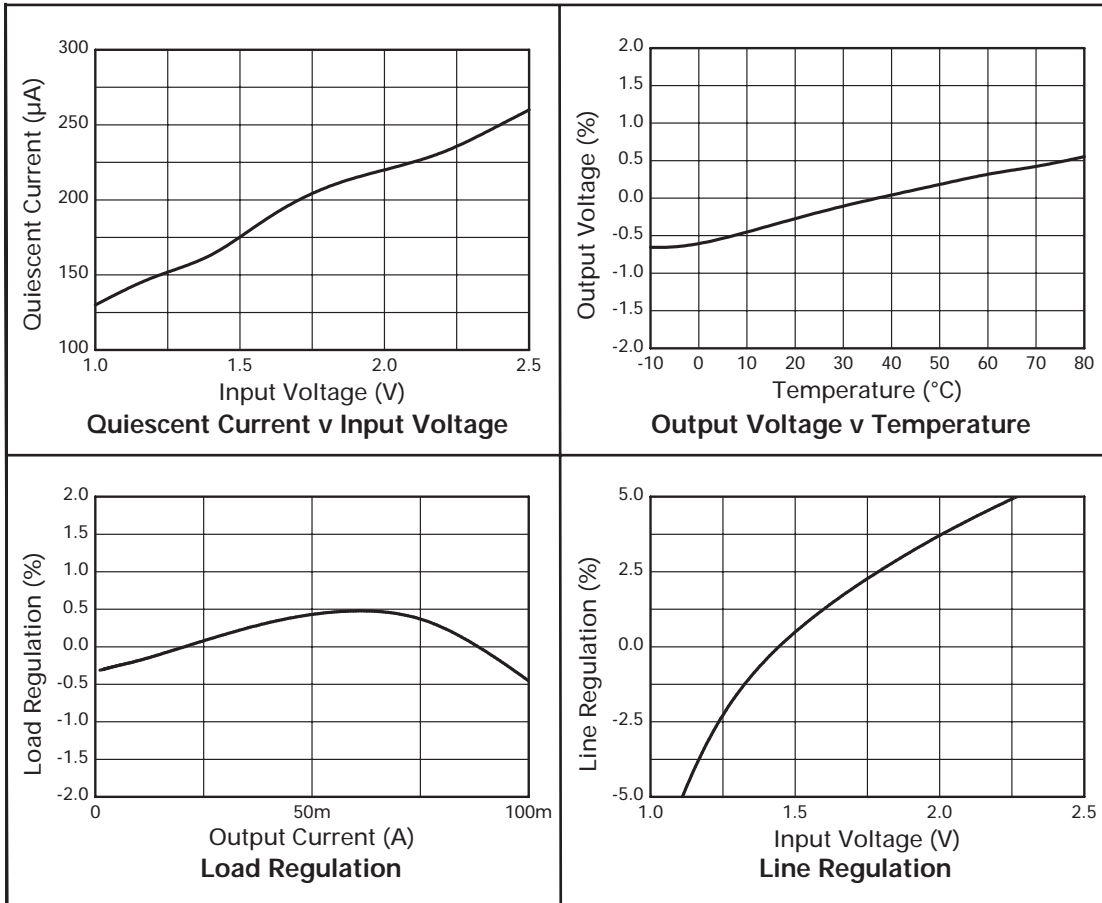

# ZXSC100

## DEVICE DESCRIPTION

The ZXSC100 is non-synchronous PFM, DC-DC controller IC which, when combined with a high performance external transistor, enables the production of a high efficiency boost converter for use in single cell applications. A block diagram is shown for the ZXSC100 in Figure 1.

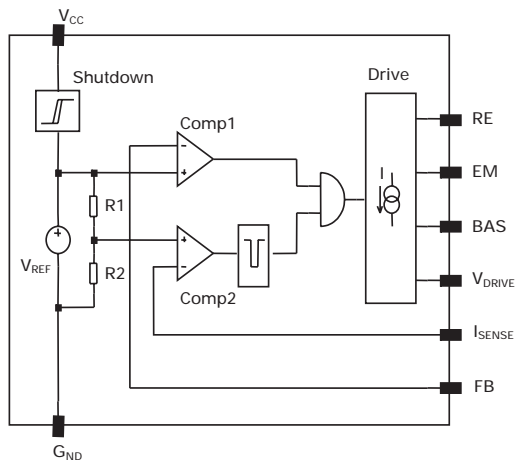

**Figure 1**  
**ZXSC100 Block Diagram**

A shutdown circuit turns the device on or off at  $V_{CC}=1V$  with a hysteresis of typically 80mV. At start up, comparator Comp1 turns the driver circuit and therefore the external switching transistor on. This circuit will remain active until the feedback voltage at the pin FB rises above  $V_{REF}$ , which is set to 730mV. An external resistive divider on the FB pin sets the output voltage level.

Comparator Comp2 forces the driver circuit and the external switching transistor off, if the voltage at  $I_{SENSE}$  exceeds 25mV. The voltage at  $I_{SENSE}$  is taken from a current sense resistor connected in series with the emitter of the switching transistor.

A monostable following the output of Comp2 extends the turn-off time of the output stage by a minimum of 2 $\mu$ s. This ensures that there is sufficient time to discharge the inductor coil before the next on period. The AND gate between the monostable and Comp1 output ensures that the switching transistor always remains on until the  $I_{SENSE}$  threshold is reached and that the minimum discharge period is always asserted. The pulse width is constant, the pulse frequency varies with the output load.

The driver circuit supplies the external switching transistor with a defined current, which is programmed by an external resistor connected between the RE pin and  $V_{CC}$ . The internal reference voltage for the circuit is 25mV below  $V_{CC}$ . To maximise efficiency the external transistor is switched quickly, typically being forced off within 20ns.

In higher power applications more current can be supplied to the switching transistor by using a further external component. The driver transistor in the IC can be bypassed with the addition of a discrete PNP. More information on this circuit configuration can be found in the applications section.

# ZXSC100

## PIN DESCRIPTIONS

Pin No.	Name	Description
1	EM	Emitter of internal drive transistor. Connect to RE in lower power applications. Must be unconnected in higher power applications
2	BAS	Not connected in lower power applications. Connect to base of external drive transistor in higher power applications
3	RE	Drive current sense input. Internal threshold voltage set 25mV below $V_{CC}$ . Connected external sense resistor. Connect emitter of external drive transistor in higher power applications
4	$V_{CC}$	Supply voltage, generally NiMH, NiCd single cell
5	$I_{SENSE}$	Inductor current sense input. Internal threshold voltage set to 25mV. Connect external sense resistor
6	FB	Feedback sense. Internal threshold set to 730mV. Connect external resistive divider to output voltage
7	$G_{ND}$	Ground

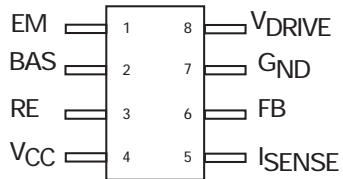

## REFERENCE DESIGNS

Three typical DC-DC step-up converter applications for the ZXSC300 are shown. Firstly with a maximum output power of 0.33W, secondly with a maximum

output power of 1.0W and finally driving white LED's in a flashlight application.

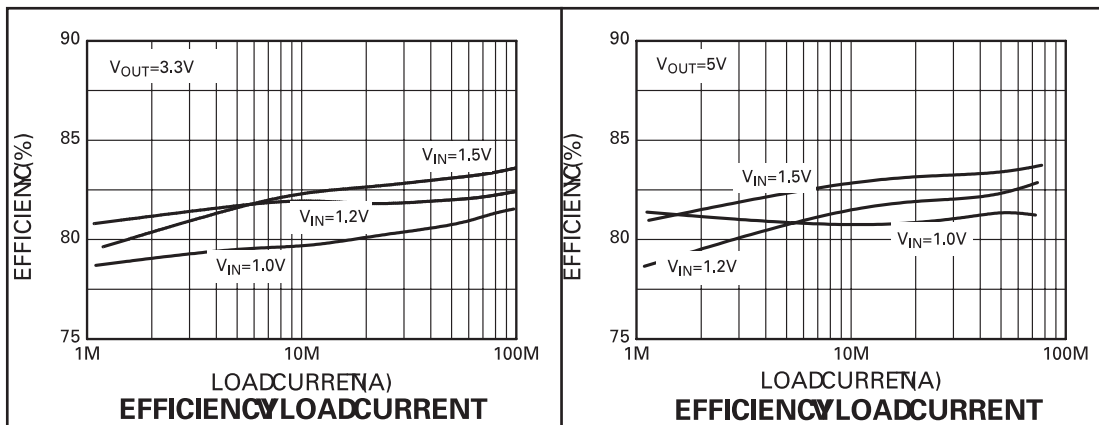

Low power solution (330mW) efficiency

# ZXSC100

Low power solution,  $V_{OUT}=3.3V$ ,  $P_L=0.33W$

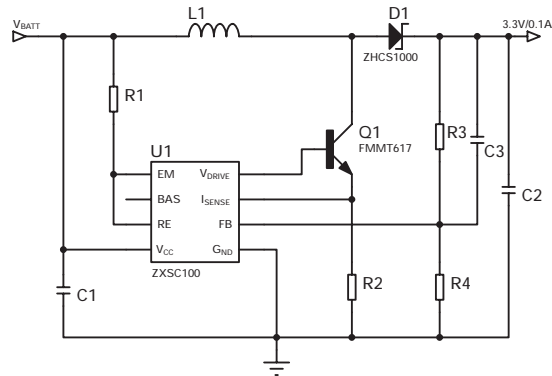

## MATERIALS LIST

Ref	Value	Part Number	Manufacturer	Comments
U1	N/A	ZXSC100X8	Zetex Plc	Single cell converter, MSOP8
Q1	20V, 13mΩ, 7A	FMMT617	Zetex Plc	Low VCE(sat) NPN, SOT23
D1	0.5V, 2A	ZHCS1000	Zetex Plc	1A Schottky diode
R1	0Ω*	Generic	Various	0805 Size
R2	33mΩ	Generic	Various	0805 Size
R3	110kΩ	Generic	Various	0805 Size
R4	30kΩ	Generic	Various	0805 Size
C1	220μF	TPSD227M010R0100	AVX	Low ESR tantalum capacitor
C2	220μF	TPSD227M010R0100	AVX	Low ESR tantalum capacitor
C3	1nF	Generic	Various	0805 Size
L1	22μH	D01608C-223 D03316P-223	Coilcraft	Low profile SMT

\* Note: Refer to External Transistor base drive selection in the Applications Section.

# ZXSC100

Higher power solution,  $V_{OUT}=3.3V$ ,  $P_L=1W$

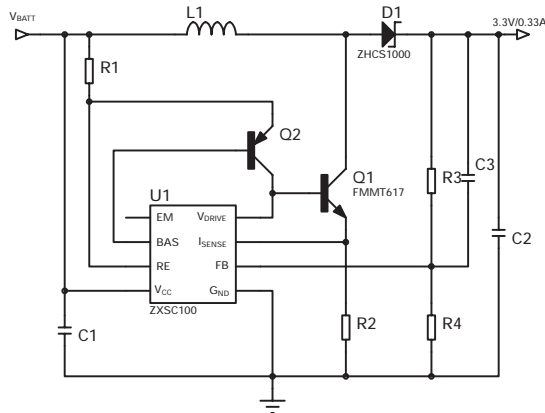

## MATERIALS LIST

Ref	Value	Part Number	Manufacturer	Comments
U1	N/A	ZXSC100X8	Zetex Plc	Single cell converter, MSOP8
Q1	20V, 13mΩ, 7A	FMMT617	Zetex Plc	Low VCE(SAT) NPN, SOT23
Q2	N/A	2N2907	Various	Small signal transistor
D1	0.5V, 2A	ZHCS1000	Zetex Plc	1A Schottky diode
R1	3.3Ω*	Generic	Various	0805 Size
R2	33mΩ	Generic	Various	0805 Size
R3	110kΩ	Generic	Various	0805 Size
R4	30kΩ	Generic	Various	0805 Size
C1	220μF	TPSD227M010R0100	AVX	Low ESR tantalum capacitor
C2	220μF	TPSD227M010R0100	AVX	Low ESR tantalum capacitor
C3	1nF	Generic	Various	0805 Size
L1	22μH	D01608C-223 D03316P-223	Coilcraft	Low profile SMT

\* Note: Refer to External Transistor base drive selection in the Applications Section.



# ZXSC100

## OTHER APPLICATIONS

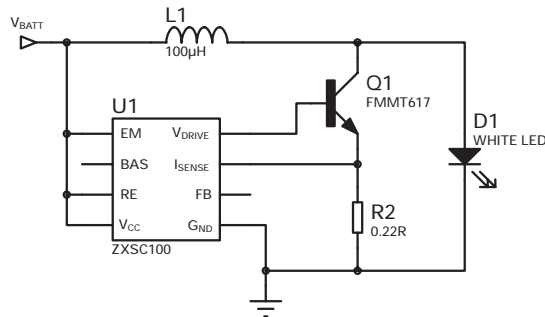

### Driving white LED's in a flashlight application

The ZXSC100 solution is ideal for LED lamp driving applications operating from a single cell. In principal conversion from 1.2V to the 3.6V, typically required by white LEDs, is necessary. Load currents in the region of 20mA to 50mA being required for a single LED element.

To minimise size, weight and cost, single cell operation is an advantage. The ZXSC is well matched to single cell NiCd and NiMH characteristics. The circuit will turn on at 1.06V, to maximise the life the battery can offer, the converter does not turn off until the battery voltage falls to 0.93V.

The circuit itself is very simple, a minimum number of components are used and they are all small size. The ZXSC uses the very small MSOP8 package, the pass transistor is SOT23. No capacitors are required as the circuit is stable under all conditions. The inductor recommended is a low cost miniature component.

No compromise is made on efficiency however. In a standard configuration efficiency well over 80% can be achieved. With careful inductor selection efficiency over 90% is possible.

The inherent flexibility of the ZXSC circuit means that parallel or series LEDs can be driven depending on application needs. A simple modification to the application circuit means that the maximum pulse current can be programmed to match the characteristics of the chosen LED load, pulse current in the range 10mA to 3A and beyond can be easily achieved.

An application note (AN33) is available describing various circuits for driving white LEDs. This application note includes details of circuits that optimise battery life, maximise brightness and can be constructed for minimal cost. Contact your local Zetex office for further details.

# ZXSC100

## APPLICATIONS INFORMATION

The following section is a design guide for optimum converter performance.

### Switching transistor selection

The choice of switching transistor has a major impact on the DC-DC converter efficiency. For optimum performance, a bipolar transistor with low  $V_{CE(SAT)}$  and high gain is required. The majority of losses in the transistor are, 'on-state' and can be calculated by using the formula below:

$$P_{Q1} = \frac{((I_{AV} \times V_{CE(SAT)}) + (I_B \times V_{BE(SAT)})) \times T_{ON}}{(T_{ON} + T_{OFF})}$$

$$\text{where } I_{AV} = \frac{I_{PK}}{2}$$

From the calculations above the impact on converter efficiency can be seen.

### External drive transistor selection

For higher power applications an external transistor is required to provide the additional base drive current to the main switching transistor. For this, any small signal PNP transistor is sufficient. Please see reference designs for recommended part numbers.

### Inductor selection

### Schottky diode selection

As with the switching transistor the Schottky rectifier diode has a major impact on the DC-DC converter efficiency. A Schottky diode with a low forward voltage and fast recovery time should be used for this application. The majority of losses in the diode are, 'on-state' and can be calculated by using the formula below:

$$P_{D1} = \frac{I_{AV} \times V_{F(MAX)} \times T_{DIS}}{(T_{ON} + T_{OFF})}$$

$$\text{where } I_{AV} = \frac{I_{PK}}{2}$$

The diode should be selected so that the maximum forward current is greater or equal to the maximum peak current in the inductor, and the maximum reverse voltage is greater or equal to the output voltage.

The Zetex ZHCS1000 meets these needs. A data sheet for the ZHCS1000 is available on the Zetex web site or through your local Zetex sales office. Outline information is included in the characteristics section of this data sheet.

# ZXSC100

The inductor value must be chosen to satisfy performance, cost and size requirements of the overall solution. For the reference designs we recommend an inductor value of 22µH with a core saturation current rating greater than the converter peak current value.

Inductor selection has a significant impact on the converter efficiency. For applications where efficiency is critical, a 5% improvement can be achieved with a high performance inductor. This should be selected with a core saturation current rating much higher than the peak current of the converter, say 3 times greater. The resultant reduction in core losses brings about the efficiency improvement.

### Peak current definition

The peak current rating is a design parameter whose value is dependent upon the overall application. For the reference designs, a peak current of 1.2A was chosen to ensure that the converter could provide the required output power.

In general, the  $I_{PK}$  value must be chosen to ensure that the switching transistor, Q1, is in full saturation with maximum output power conditions, assuming worst-case input voltage and transistor gain under all operating temperature extremes.

Once  $I_{PK}$  is decided the value of  $R_{SENSE}$  can be determined by:

$$R_{SENSE} = \frac{V_{ISENSE}}{I_{PK}}$$

### Output power definition

By making the above assumptions for the inductor and  $I_{PK}$  the output power can be determined by:

$$\text{Output Power} = \frac{(V_{OUT} - V_{IN}) \times I_{PK} \times T_{DIS}}{2 \times (T_{ON} + T_{OFF})}$$

where

$$T_{ON} = \frac{I_{PK} \times L}{V_{IN}}$$

and

$$T_{DIS} = \frac{I_{PK} \times L}{(V_{OUT} - V_{IN})}$$

Note:  $V_{OUT}$  = output voltage + rectifier diode VF

Figure 3 shows the discontinuous inductor current and the relationship between output power,  $T_{ON}$ ,  $T_{DIS}$  and  $T_{OFF}$ .

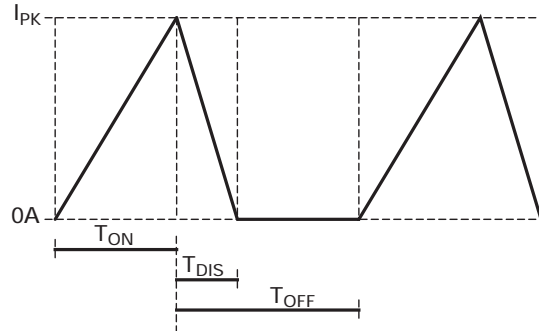

**Figure 3**  
Discontinuous inductor current

### Output capacitors

Output capacitors are a critical choice in the overall performance of the solution. They are required to filter the output and supply load transient currents. There are three parameters which are paramount in the selection of the output capacitors; their capacitance value,  $I_{RIPPLE}$  and ESR. The capacitance value is selected to meet the load transient requirements. The capacitors  $I_{RIPPLE}$  rating must meet or exceed the current ripple of the solution.

The ESR of the output capacitor can also affect loop stability and transient performance. The capacitors selected for the solution, and indicated in the reference designs, are optimised to provide the best overall performance.

# ZXSC100

## Input capacitors

The input capacitor is chosen for its voltage and RMS current rating. The use of low ESR electrolytic or tantalum capacitors is recommended. Capacitor values for optimum performance are suggested in the reference design section.

Also note that the ESR of the input capacitor is effectively in series with the input and hence contributes to efficiency losses in the order of  $I_{RMS}^2 \times ESR$ .

## Output voltage adjustment

The ZXSC100 is an adjustable converter allowing the end user the maximum flexibility in output voltage selection. For adjustable operation a potential divider network is connected as indicated in the diagram.

The output voltage is determined by the equation:

$$V_{OUT} = V_{FB} (1 + RA / RB),$$

where  $V_{FB} = 730mV$

The resistor values, RA and RB, should be maximised to improve efficiency and decrease battery drain. Optimisation can be achieved by providing a minimum current of  $I_{FB(MAX)} = 200nA$  to the  $V_{BATT}$  pin. The output is adjustable from  $V_{FB}$  to the  $(BR)V_{CEO}$  of the switching transistor, Q1.

Note: For the reference designs, RA is assigned the label R3 and RB the label R4.

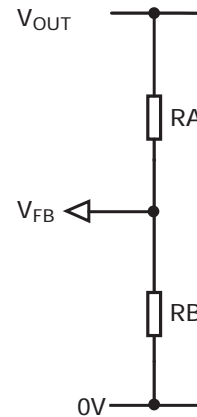

## External transistor base drive selection

Optimisation of the external switching transistor base drive may be necessary for improved efficiency in low power applications. This can be achieved by introducing an external resistor between the supply and the RE pin of the ZXSC300. The resistor value can be determined by:

$$R_1 = \frac{V_{DREF}}{I_B}$$

# ZXSC100

## Layout issues

Layout is critical for the circuit to function optimally in terms of electrical efficiency, thermal considerations and noise.

For 'step-up converters' there are four main current loops, the input loop, power-switch loop, rectifier loop and output loop. The supply charging the input capacitor forms the input loop. The power-switch loop is defined when Q1 is 'on', current flows from the input through the inductor, Q1, R<sub>SENSE</sub> and to ground. When Q1 is 'off', the energy stored in the inductor is transferred to the output capacitor and load via D1, forming the rectifier loop. The output loop is formed by the output capacitor supplying the load when Q1 is switched back off.

To optimise for best performance each of these loops should be kept separate from each other and interconnections made with short, thick traces thus

minimising parasitic inductance, capacitance and resistance. Also the sense resistor R2 should be connected, with minimum trace length, between emitter lead of Q1 and ground, again minimising stray parasitics.

The layout for the 0.33W solution is shown below.

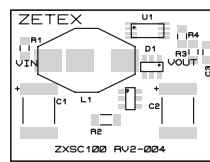

Actual Size

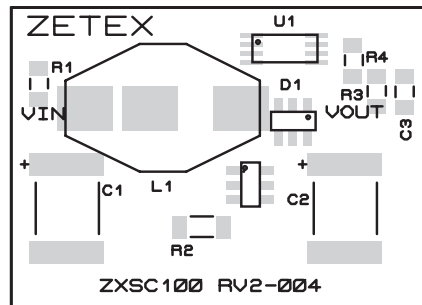

Top silk

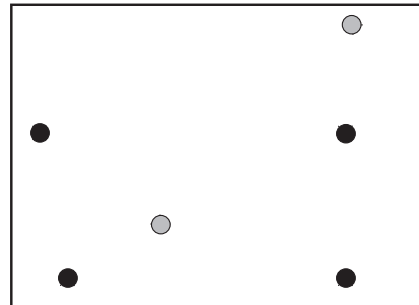

Drill holes

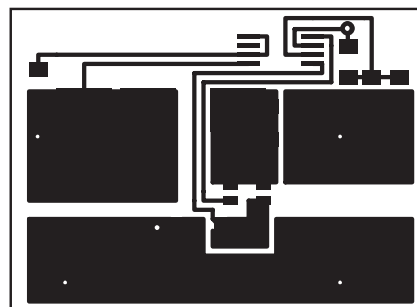

Top Copper

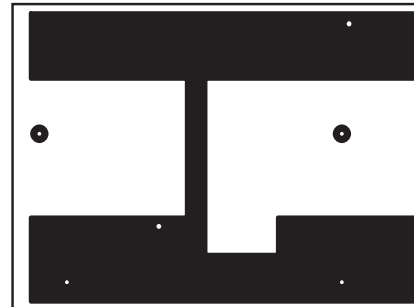

Bottom Copper

0.33W solution demo board layout

# ZXSC100

## Designing with the ZXSC100

### Introduction

This section refers to the ZXSC100, 3.3V/100mA output reference design and demonstrates the dynamic performance of the solution.

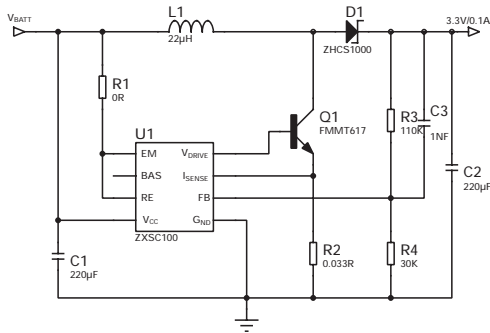

Figure 1. ZXSC100 low power solution, 3.3V/100mA output.

### Efficiency

Efficiency is often quoted as one of the key parameters of a DC-DC converter. Not only does it give an instantaneous idea of heat dissipation, but also an idea as to the extent battery life can be extended. Figure 2. Shows the efficiency of the ZXSC100 low power solution. Efficiency v Output current is shown for a 3.3V output at various input voltages.

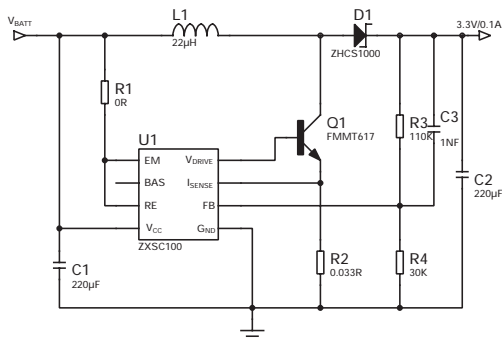

Figure 2. ZXSC100 efficiency v output current

### Main switching waveforms

Steady state operation under constant load gives an excellent indication of ZXSC100 performance. Represented in Figure 3. is the main switching waveform, measured at the collector of Q1, indicating the transistor on-state and the diode energy transfer to the output.

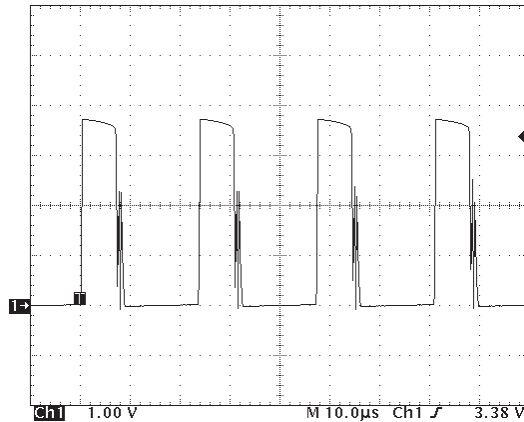

Figure 3. Switching waveform

The peak switching current is derived from the threshold of the I\_SENSE pin and the sense resistor value (see Applications section for calculations). Figure 4. shows the switching waveform associated with the I\_SENSE pin

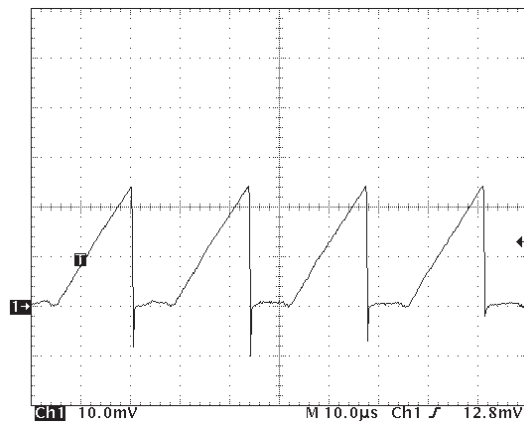

Figure 4. I\_SENSE threshold

# ZXSC100

Shown in Figure 5. is the discontinuous inductor current. The ramp-up current stores energy in the inductor. The switching transistor, Q1, is on during this time and has an equivalent current ramp-up, shown in Figure 6. The ramp-down current is associated with the energy being delivered to the output via the Schottky diode, D1. The diode current is equivalent to this ramp-down current and is shown in figure 7.

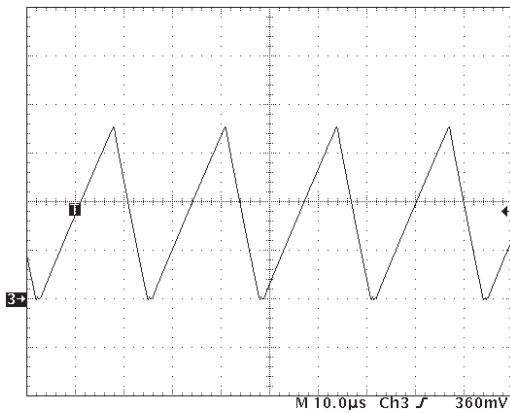

Figure 5.  
Inductor current (200mA/div)

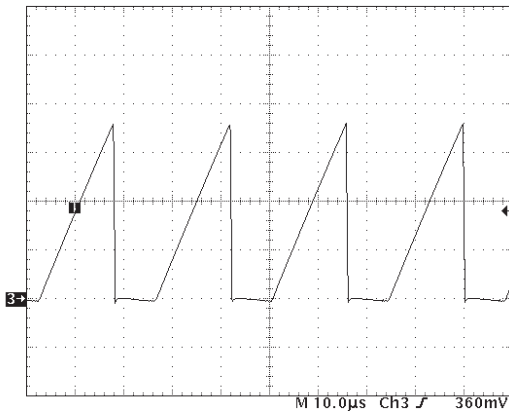
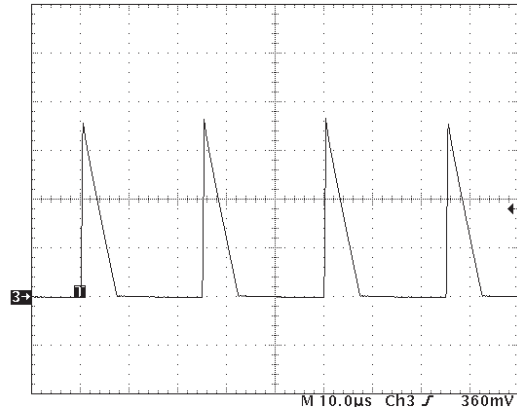

Figure 6.  
Transistor current (200mA/div)

Figure 7.  
Diode current (200mA/div)



# ZXSC100

## Output voltage ripple

Output voltage ripple is shown in Figure 8. The circuit is operated with a 1.2V input voltage, 3.3V output voltage and 100mA load current. Output voltage ripple will be dependent, to a large extent, on the output capacitor ESR. (see Applications section for recommended capacitors).

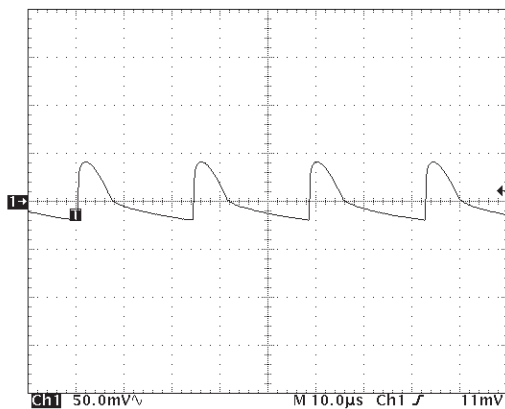

Figure 8. Output voltage ripple for 3.3V/100mA output.

## Transient response

Transient response to step changes in load is a critical feature in many converter circuits. The ZXSC100 operates a pulse by pulse regulation scheme and therefore corrects for changes in the output every pulse cycle, giving excellent response characteristic.

## Measurement with a power supply

When measuring with a power supply it is important to realise that the impedance is much greater than that of a secondary battery (NiCd or NiMH). To simulate the lower impedance of the battery x10 low ESR 1000uF capacitors were placed in parallel at the input of the converter. All the dynamic performance measurements were taken using this technique.



# ZXSC100

## CONNECTION DIAGRAMS

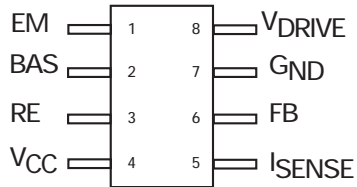

## MSOP8

DIM	Millimeters		Inches	
	MIN	MAX	MIN	MAX
A	0.91	1.11	0.036	0.044
A1	0.10	0.20	0.004	0.008
B	0.25	0.36	0.010	0.014
C	0.13	0.18	0.005	0.007
D	2.95	3.05	0.116	0.120
e	0.65NOM		0.0256NOM	
e1	0.33NOM		0.0128NOM	
E	2.95	3.05	0.116	0.120
H	4.78	5.03	0.188	0.198

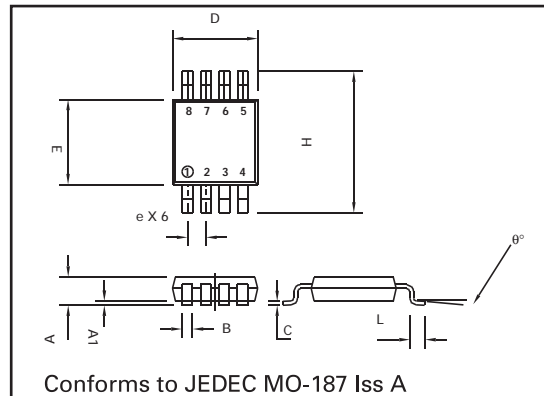

## SO8

DIM	Millimeters		Inches	
	MIN	MAX	MIN	MAX
A	4.80	4.98	0.189	0.196
B	1.27 BSC		0.05 BSC	
C	0.53 REF		0.02 REF	
D	0.36	0.46	0.014	0.018
E	3.81	3.99	0.15	0.157
F	1.35	1.75	0.05	0.07
G	0.10	0.25	0.004	0.010
J	5.80	6.20	0.23	0.24

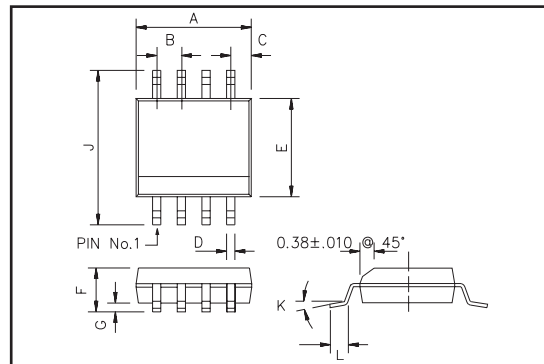

© Zetex plc 2004

Europe	Americas	Asia Pacific	Corporate Headquarters
Zetex GmbH Streitfeldstraße 19 D-81673 München Germany	Zetex Inc 700 Veterans Memorial Hwy Hauppauge, NY 11788 USA	Zetex (Asia) Ltd 3701-04 Metroplaza Tower 1 Hing Fong Road, Kwai Fong Hong Kong	Zetex plc Fields New Road, Chadderton Oldham, OL9 8NP United Kingdom
Telephone: (49) 89 45 49 49 0 Fax: (49) 89 45 49 49 49 europe.sales@zetex.com	Telephone: (1) 631 360 2222 Fax: (1) 631 360 8222 usa.sales@zetex.com	Telephone: (852) 26100 611 Fax: (852) 24250 494 asia.sales@zetex.com	Telephone (44) 161 622 4444 Fax: (44) 161 622 4446 hq@zetex.com

These offices are supported by agents and distributors in major countries world-wide.

This publication is issued to provide outline information only which (unless agreed by the Company in writing) may not be used, applied or reproduced for any purpose or form part of any order or contract or be regarded as a representation relating to the products or services concerned. The Company reserves the right to alter without notice the specification, design, price or conditions of supply of any product or service.

For the latest product information, log on to [www.zetex.com](http://www.zetex.com)

ISSUE 3 - JANUARY 2004